

# Appendices

## List of Appendices

Appendix A: [Drilling Blowout Prevention Systems](#)

Appendix B: [Diagrams of Blowout Prevention Systems for Well Servicing](#)

Appendix C: [Alert for Operators Drilling in Quaternary Gravels](#)

Appendix D: [Classification of Low and Medium Risk Gas Wells](#)

Appendix E: [Technical Guidance for Determining the “Base of Usable Groundwater”](#)

Appendix F: [Facility Changes Requiring an Amendment](#)

Appendix G: [Facility Changes Where No Amendment or NOI is Needed](#)

Appendix H: [Piping and Instrumentation Diagram \(P&ID\)](#)

Appendix I: Sour Well Information Form

[Appendix J: Benzene Emissions from Glycol Dehydrators](#)

## Appendix A: Drilling Blowout Prevention Systems

### Blow-Out Prevention Stack

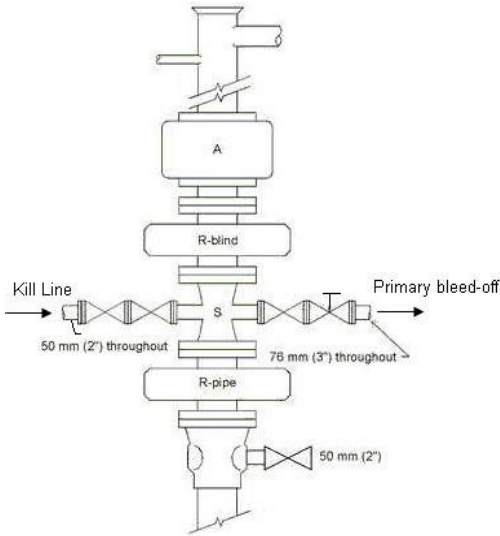

### CLASS A

Surface Casing Depth - 1,800 metres (14,000-21,000 kPa).

Drilling Blowout Prevention System for Wells not exceeding a True Vertical Depth of 1,800 metres.

Minimum pressure rating: 14,000 kPa (2,000 psi).

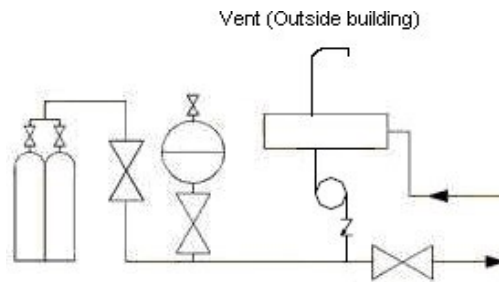

### Accumulator System

#### Notes:

- Bleed-off line, centreline through choke manifold, and flare line must be a minimum nominal diameter of 76.2mm throughout.
- Lines through chokes must be a minimum nominal diameter of 50.8mm throughout.
- Kill line must be a minimum nominal diameter of 50.8mm throughout.
- Flanged pipe connections must be used from the drilling spool down to and including the connection to the choke manifold. The remainder of the choke manifold may contain threaded fittings.
- Minimum pressure rating for flares and degasser inlet lines is 14MPa.
- Hydraulic and manual valve positions in the bleed-off line may be interchangeable
- Ram type BOPs manufactured with integral outlets may be used in place of drilling spool, but must be inspected and re-certified if significant flow occurs through the body.

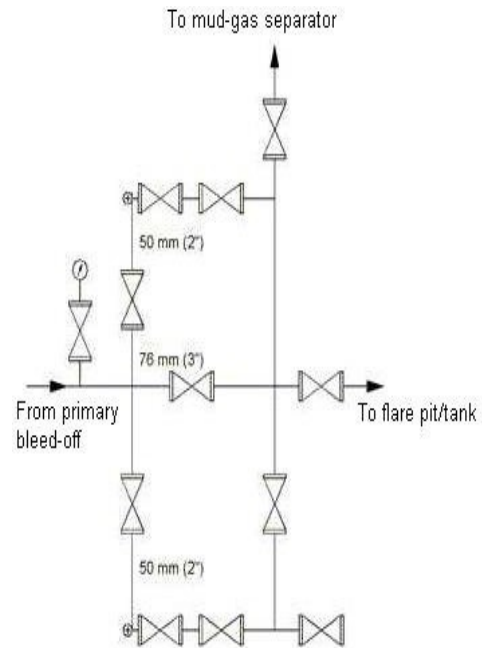

### Choke Manifold

**CLASS B**

1,800-3,000 metres.

Drilling Blowout Prevention System for Wells not exceeding a True Vertical Depth of 3,000 metres.

Minimum pressure rating 21,000 kPa (3,000 psi).

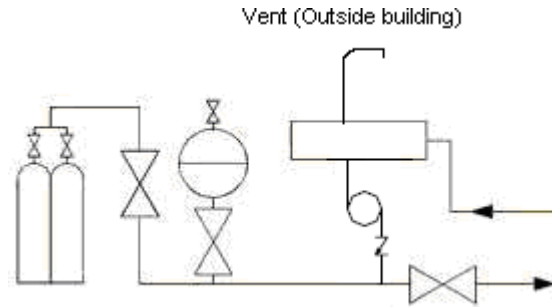
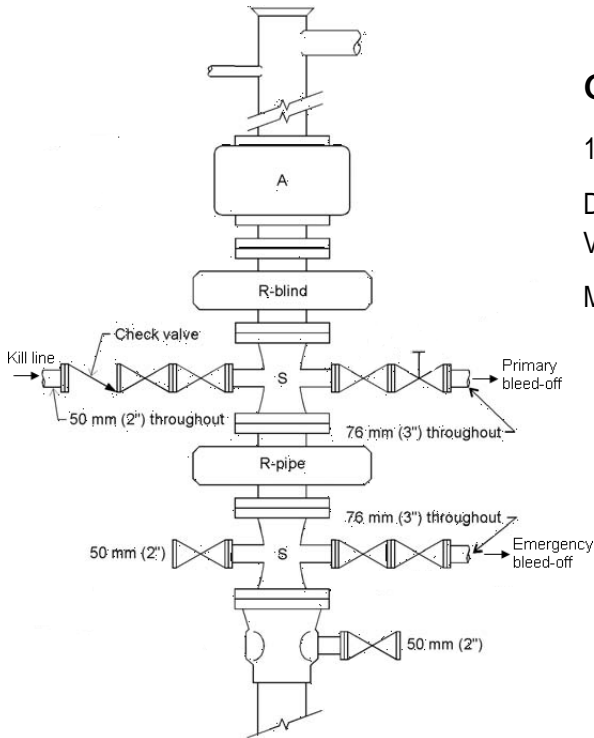

**Accumulator System**

**Blow-out Prevention Stack**

**Notes:**

- Bleed-off line, centreline through choke manifold, and flare line must be a minimum nominal diameter of 76.2mm throughout.
- Lines through chokes must be minimum nominal diameter of 50.8mm throughout.
- Kill line must be a minimum nominal diameter of 50.8mm throughout.
- Flanged pipe connections must be used from the drilling spool to the last valve on the choke manifold, inclusive
- Welded flanges required to connect primary and emergency bleed-off lines.
- Minimum pressure rating for flare and degasser lines is 14MPa.
- Hydraulic and manual valve positions in the bleed-off line may be interchangeable
- Ram type BOPs manufactured with integral outlets may be used in place of the drilling spools, but must be re-certified if significant flow has occurred through the body.

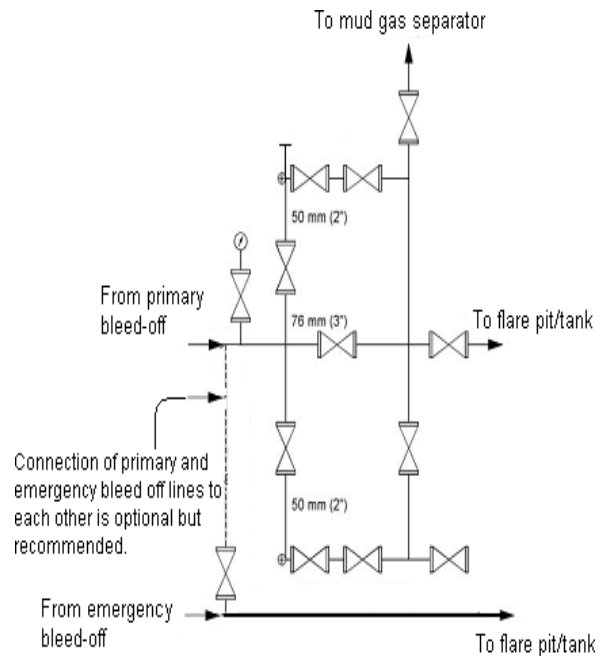

**Manifold System**

### CLASS C

3,000-5,500 metres.

Drilling Blowout Prevention System for Wells not exceeding a True Vertical Depth of 5,500 metres.

Minimum pressure rating 34,000 kPa (5,000 psi).

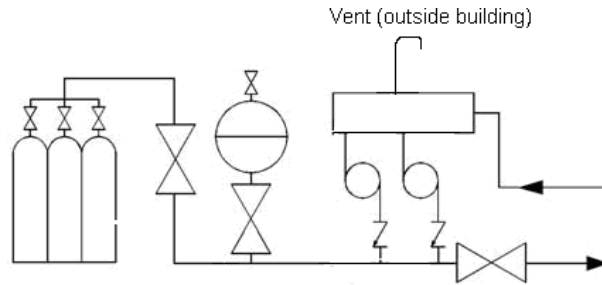
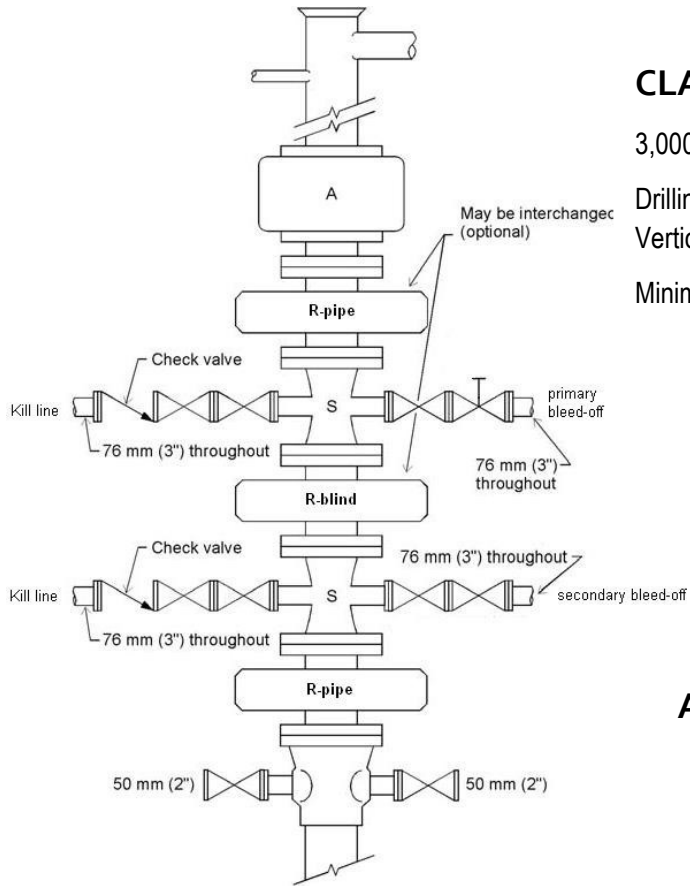

### Accumulator System

### Blow-out Prevention Stack

#### Notes:

- Kill lines, bleed-off lines, choke manifold, and flare lines must be a minimum nominal diameter of 76.2mm throughout.
- Flanged pipe connections must be used from the drilling spool to the last valve on the choke manifold, inclusive.
- Minimum pressure rating for flare and degasser lines is 14MPa.
- Hydraulic and manual valve positions in the bleed-off line may be interchangeable.
- Ram type BOPs manufactured with integral outlets may be used in place of the drilling spools, but must be re-certified if significant flow has occurred through the body.

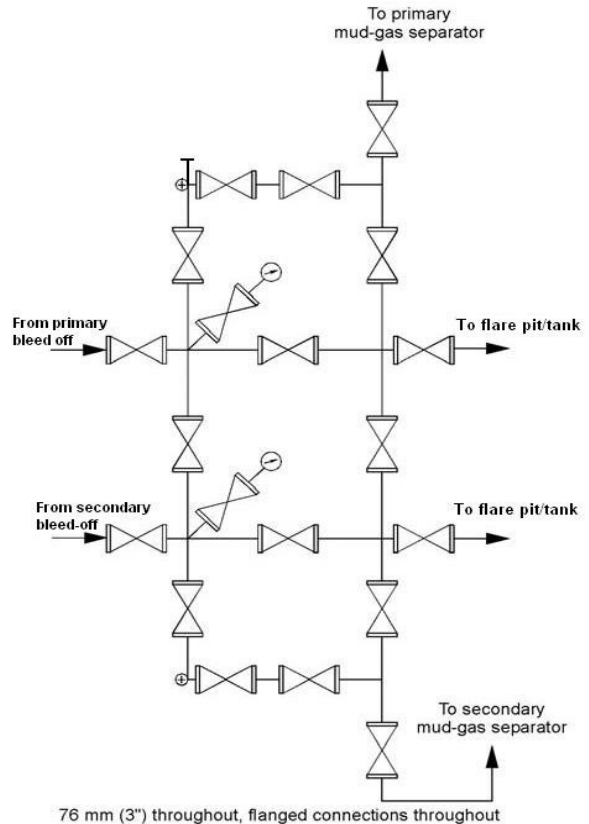

## Blow-out Prevention Stack

### CLASS D

5,500 metres and deeper.

Drilling Blowout Prevention System for Wells exceeding a True Vertical Depth of 5,500 metres.

Minimum pressure rating 70,000 kPa (10,000 psi).

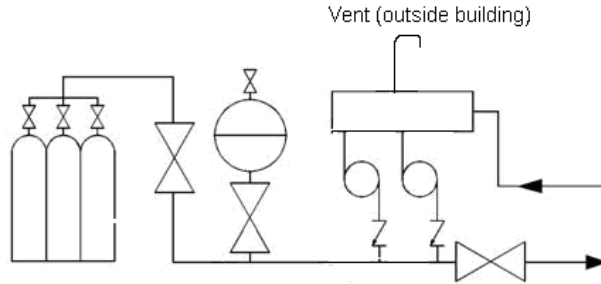
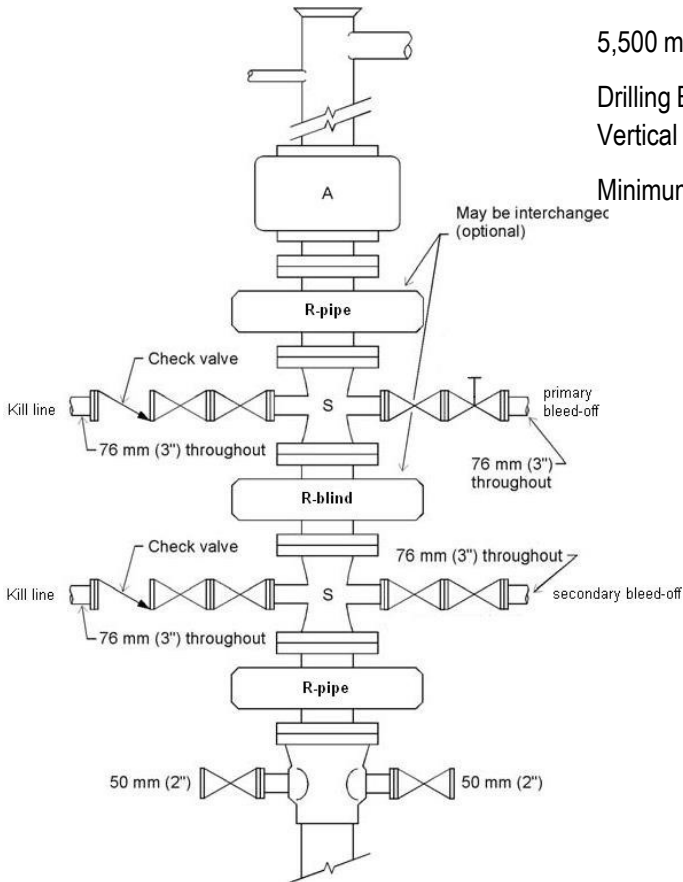

### Accumulator System

#### Notes:

- Kill lines, bleed-off lines, choke manifold, and flare lines must be a minimum nominal diameter of 76.2mm throughout.
- Flanged pipe connections must be used from the drilling spool to the last valve on the choke manifold, inclusive.
- Minimum pressure rating for flare and degasser lines is 14MPa.
- Hydraulic and manual valve positions in the bleed-off line may be interchangeable
- Ram type BOPs manufactured with integral outlets may be used in place of the drilling spools, but must be re-certified if significant flow has occurred through the body.
- Other BOP stack configurations are acceptable, including the use of double gate rams. Stack must contain a minimum of 2 pipe rams and one blind ram.

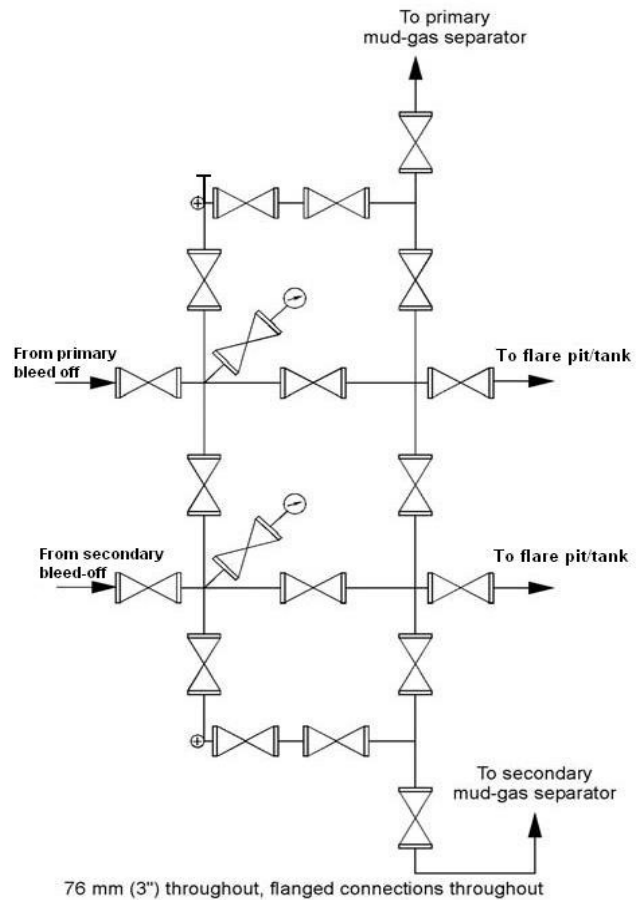

## Special Sour: All Depths

Drilling Prevention Systems for Special Sour Wells.

Minimum pressure rating 14,000 kPa (2,000 psi).

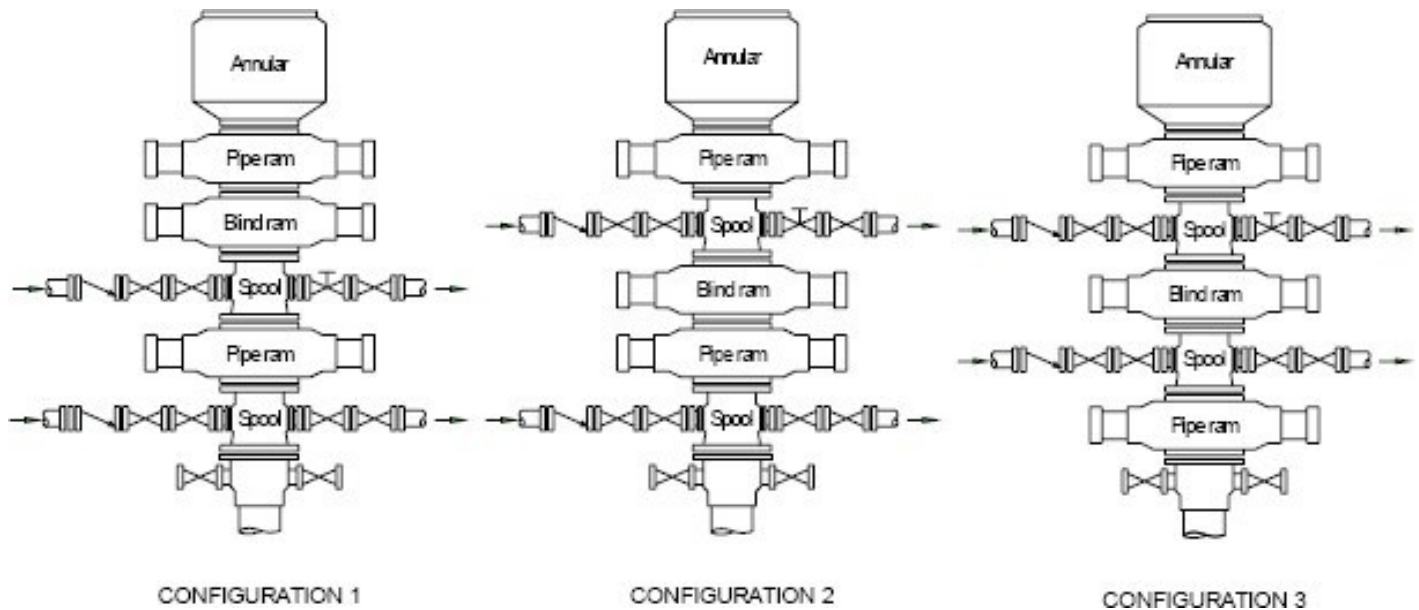

### Note:

- Hydraulic and manual valve positions in bleed-off line are interchangeable
- If BOP Configuration 2 or BOP Configuration 3 is used, an appropriately sized ram blanking tool fitting into the top pipe ram must be on location and readily available.
- If BOP Configuration 3 is used, there must be sufficient surface or intermediate casing to contain the maximum anticipated reservoir pressure.
- Shear blind rams may be required in place of the blind rams.
- Rams type BOPs manufactured with integral outlet may be used in place of the drilling spools, but must be re-certified if significant flow has occurred through the bodies.

## Special Sour Manifold

Minimum pressure rating 14,000 kPa (2,000 psi).

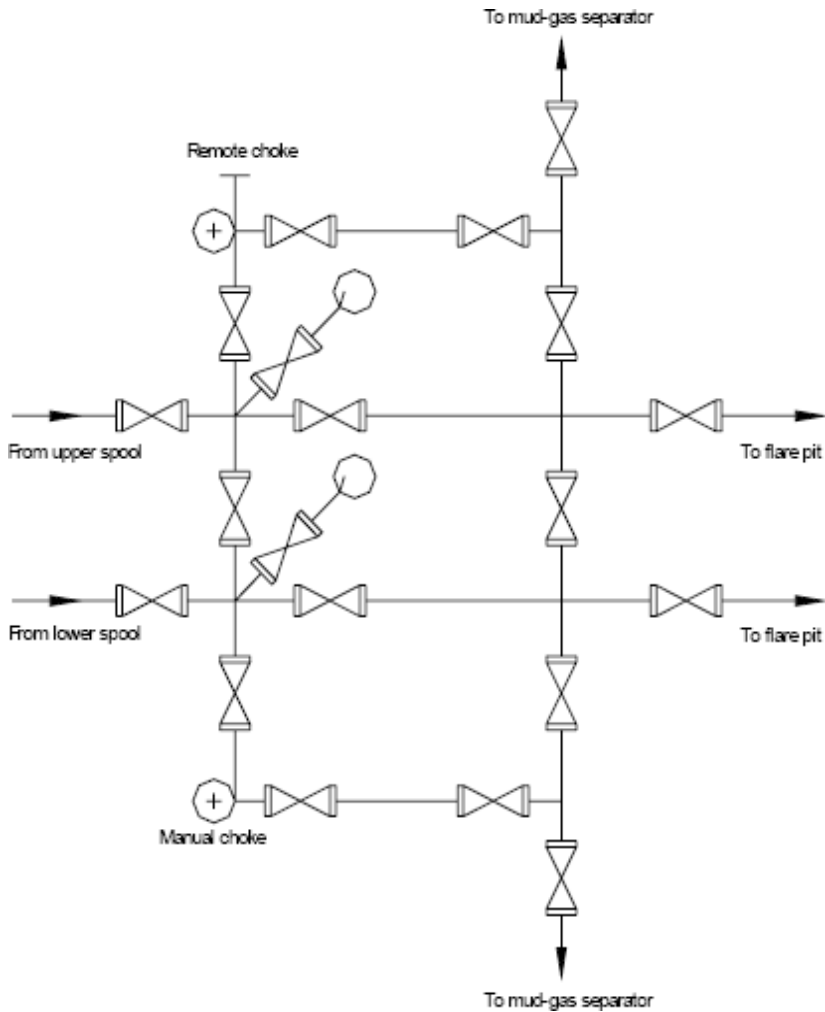

### Bleed off lines – All Classes

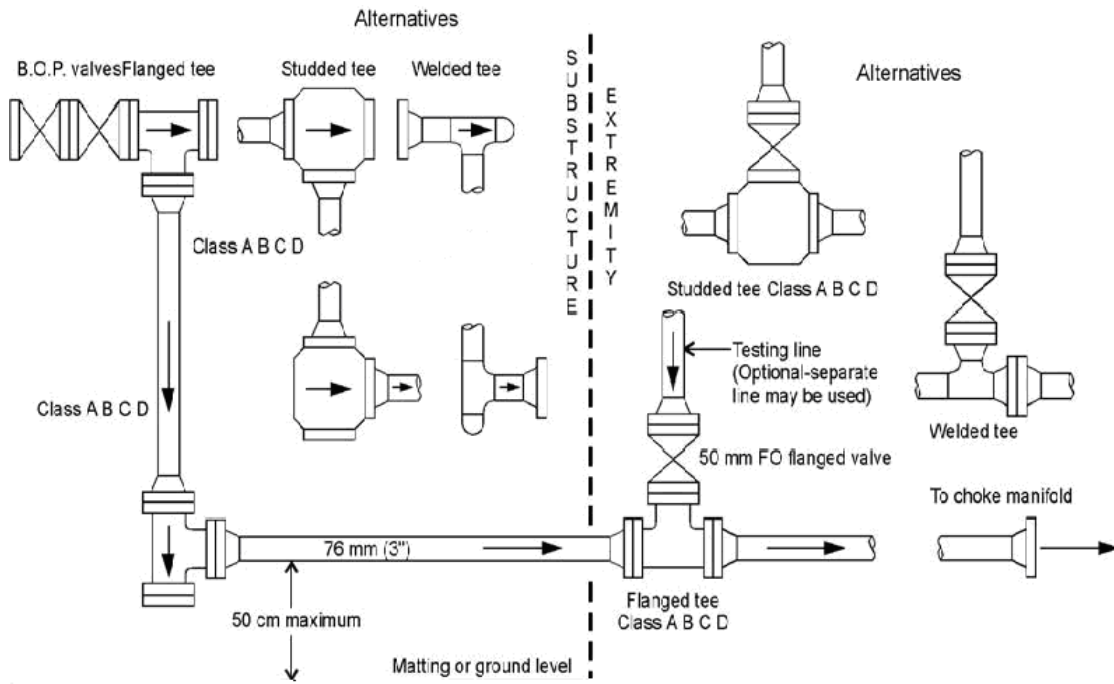



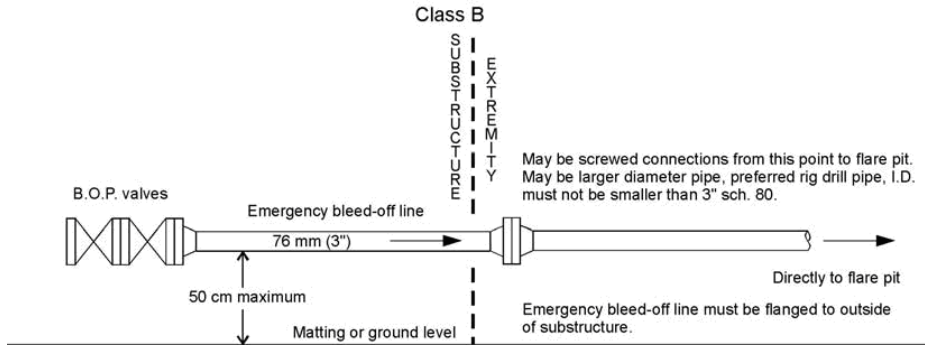

**Bleed Off Lines- Class C & D**  
**Connection of primary and emergency bleed off lines- Class B**

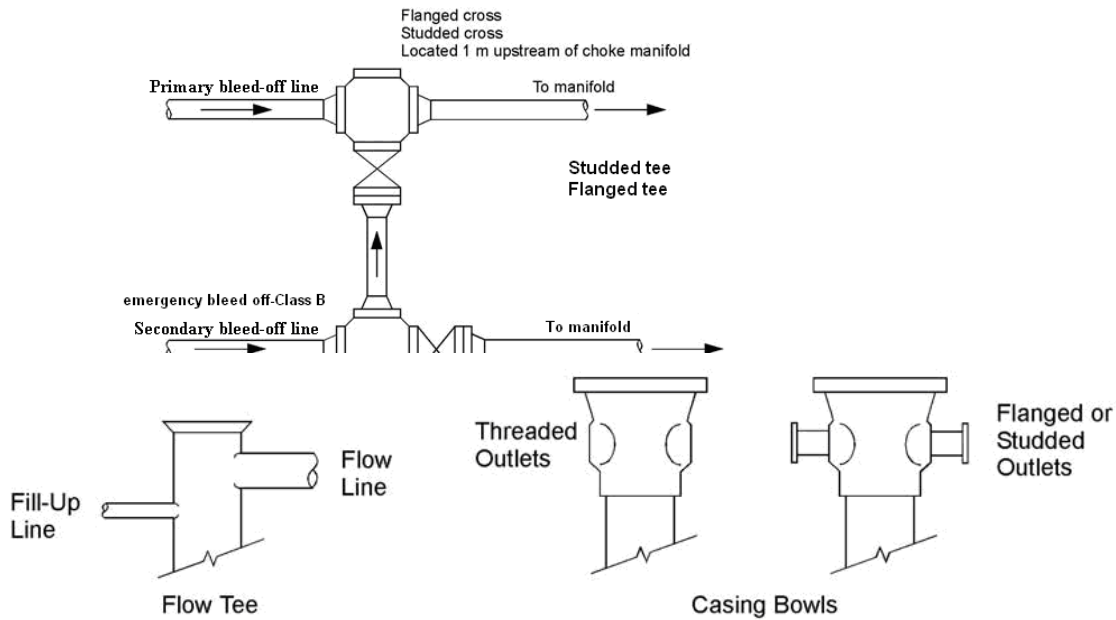

For all classes:

Class A, B, C and D diagrams indicate single ram preventer. The single blind ram preventer may be replaced with a double gate preventer.

## Equipment Symbols

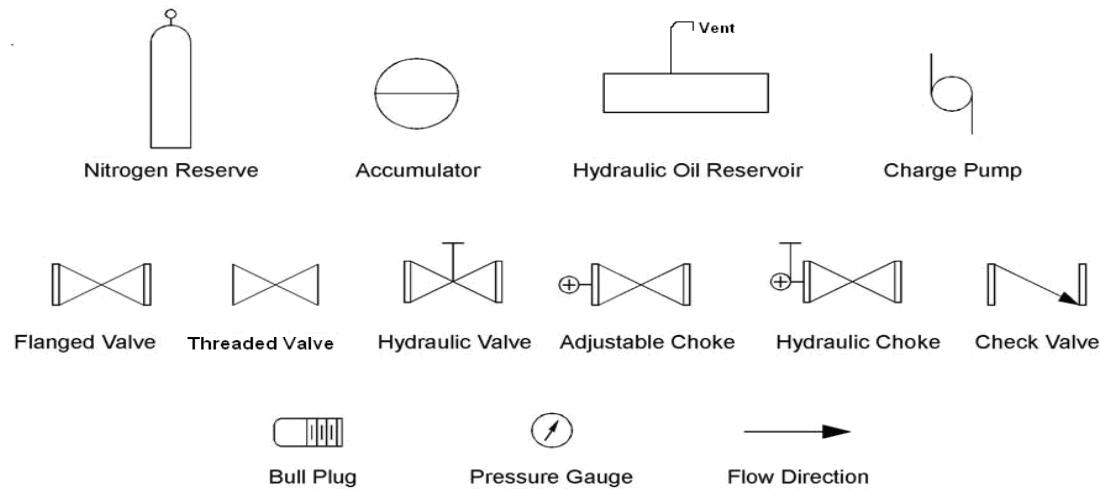

### Note:

- R – Single ram type preventer with one set of blind or pipe ram.
- A – annular-type blowout preventer.
- S – drilling spool with flanged side outlet connections for bleed-off and kill lines.
- Flanged means weld necked flanges.
- A double gate blowout preventer may replace a single gate preventer but the lowest ram in any stack shall be a pipe ram.

# Appendix B: Diagrams of Blowout Prevention Systems for Well Servicing

Figure B-1 Equipment Symbols

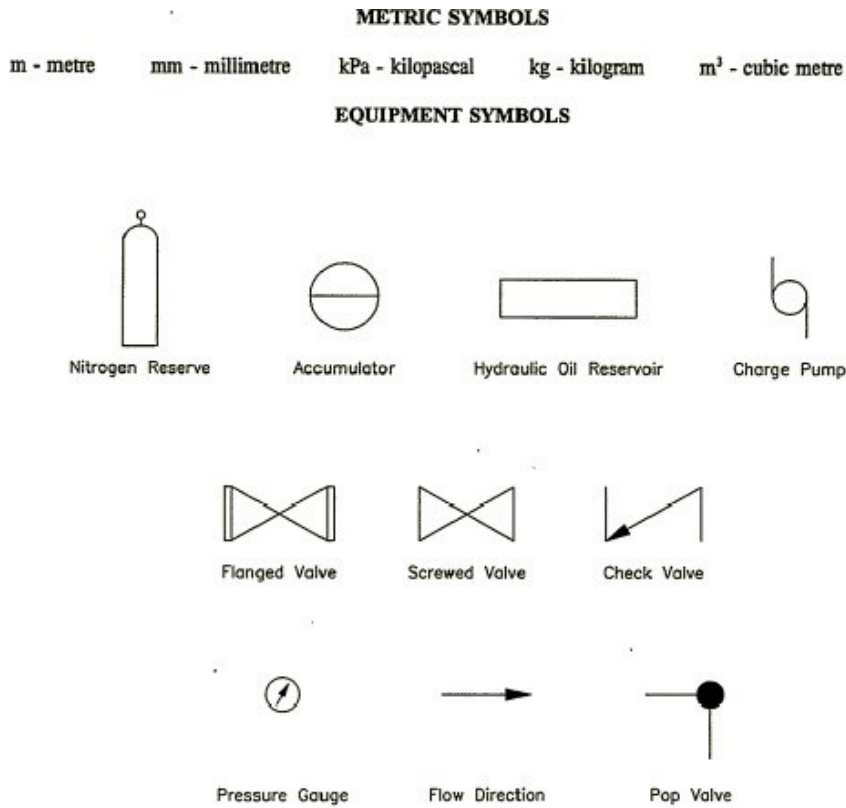

RATING OF PRODUCTION CASING FLANGE IS LESS THAN OR EQUAL TO 21000 kPa  
 $H_2S$  CONTENT OF THE GAS IS LESS THAN 10 MOLES/KILOMOLE

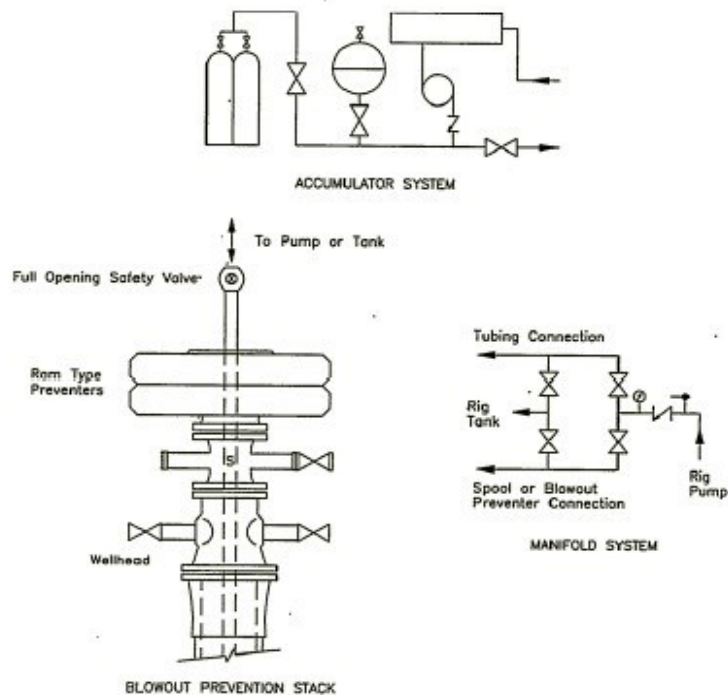

**Figure B-2: BOP Class A Pressure Rating and Component Placement**

- Pressure rating of preventers is equal to or greater than the production casing flange rating or the formation pressure, whichever is the lesser.
- 50 mm lines throughout.
- The positioning of the tubing and blind rams may be interchanged.
- Spool may have threaded side outlet (and valve) if wellhead has threaded fittings.
- A flanged BOP port (and valve) below the lowest set of rams may replace spool (valve may be threaded if wellhead has threaded fittings).

Rating of production casing flange is greater than 21 000 kPa or rating of production casing flange is less than or equal to 21 000 kPa and the  $H_2S$  content of the gas is equal to or greater than 10 MOLES per KILOMOLE.

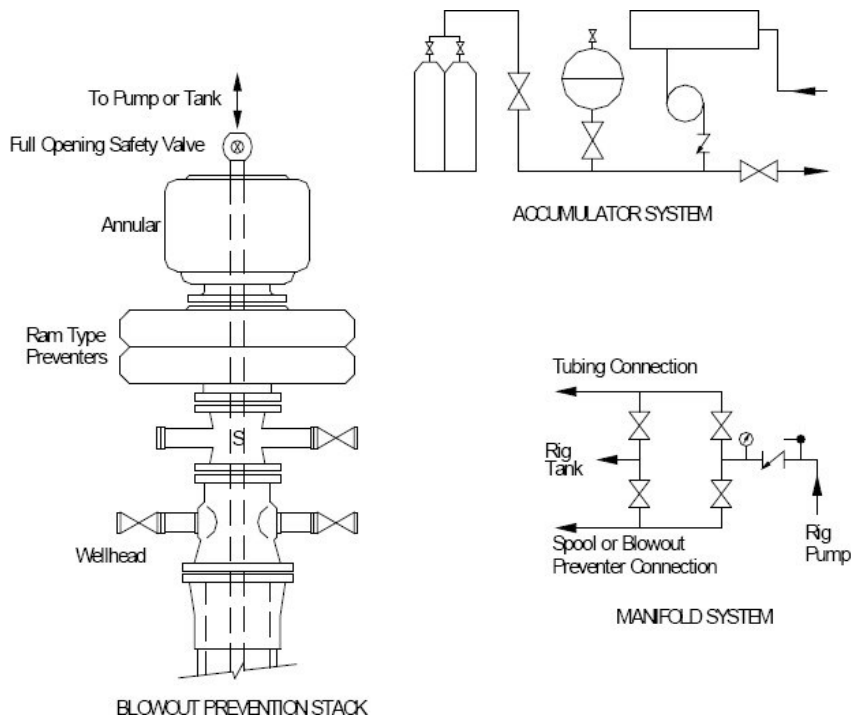

**Figure B-3: BOP Class B Pressure Rating and Component Placement**

- Pressure rating of preventers is equal to or greater than the production casing flange rating or the formation pressure, whichever is the lesser.
- 50 mm lines throughout.
- The positioning of the tubing and blind rams may be interchanged.
- Spool may have threaded side outlet (and valve) if wellhead has threaded fittings.
- A flanged blowout preventer port (and valve) below the lowest set of rams may replace spool (valve may be threaded if wellhead has threaded fittings.)

CLASS C - WELLHEAD CONFIGURATIONS  
Special sour well servicing BOP stack with shear blind ram.

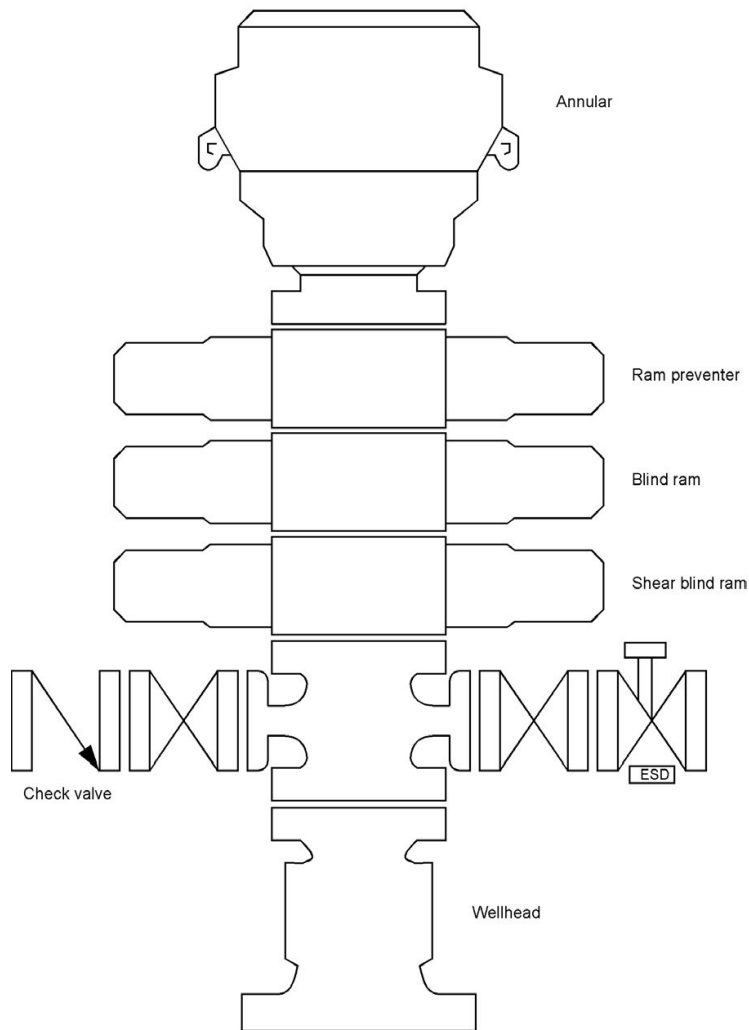

Figure B-4: BOP Class C Wellhead Configuration

CLASS C - WELLHEAD CONFIGURATIONS  
Special sour well servicing BOP stack with shear blind ram optional arrangement.

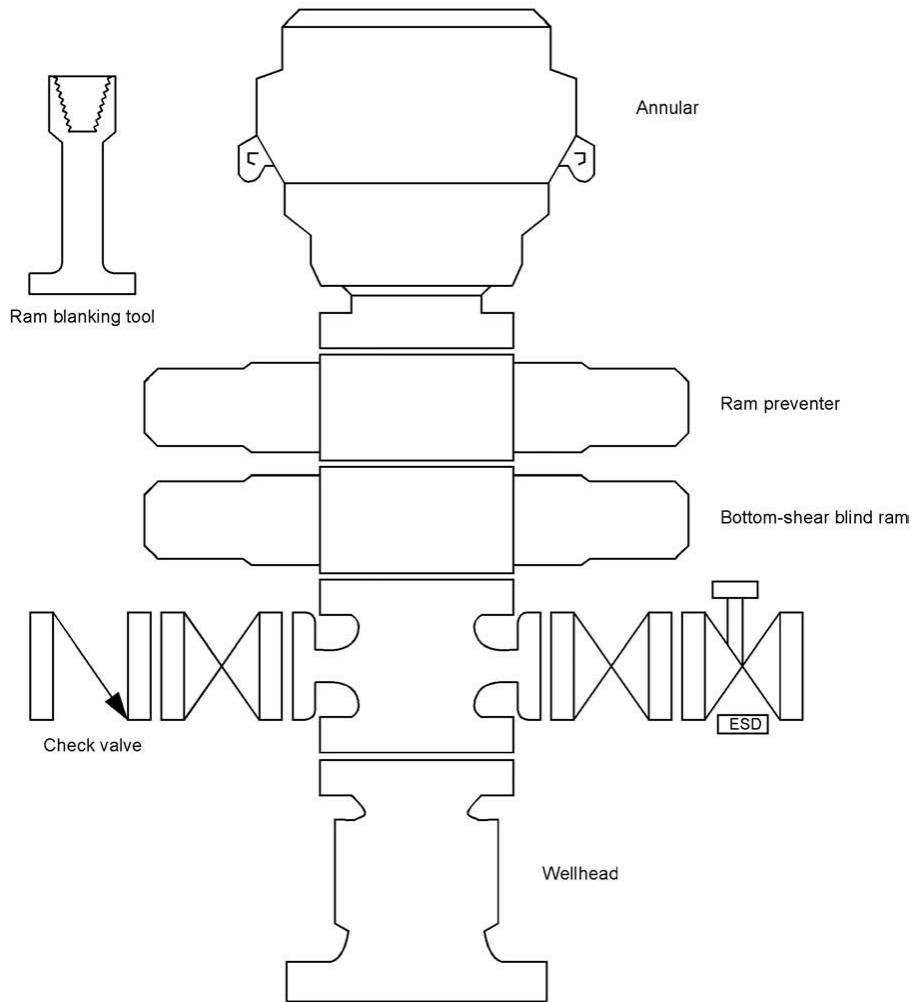

Figure B-5: BOP Class C Optional Wellhead Configuration

## Appendix C: Alert for Operators Drilling in Quaternary Gravels

Originally published as an Information Letter to alert operators drilling in Quaternary Gravels, particularly in Midwinter-Helmet North Field areas, but also in the rest of British Columbia.

### Background

On January 28, 2005 the Nabors 29 rig on the CNRL HZ Midwinter b-93-L/94-P-10 well encountered a low differential gas kick while drilling at approximately 140 m KB. The well blew out, ignited, and burned for approximately 12 hours causing one fatality and destroying the rig.

It seems the rig encountered a gas pocket in Quaternary gravels. These gravels are known to be pressured but water bearing in the northern portion of 94-P-15. The gravels have been encountered sporadically in the southern portion of 94-P-15 and the northern portion of 94-P-10. This is the first report of gas bearing Quaternary gravels within a 60 kilometre radius. No water was produced with this blowout.

### Requirements

Quaternary gravels are present throughout northeast British Columbia. Equivalent gravels at Sousa field in T112-R1W6 and Rainbow T110-R3W6 in Alberta have produced gas. ISH Energy has produced gas from the Dunvegan zone at two wells in the Desan field at c-82-K & d-81-K/94-P-2. These wells are approximately 60 kilometres south of the blowout location. A new interpretation of this zone suggests it may be Quaternary gravels.

Deposition of Quaternary gravels is generally interpreted to be glacio-fluvial sediments in bedrock erosional lows. At Sousa field, there are occurrences of four stacked gravels found in one well bore. However, researchers have found significant gravel deposits on the flanks of bedrock highs. Minor gravel deposits on the tops of bedrock highs cannot be ruled out.

The gas in these gravels has been interpreted to be biogenic gas. The blowout zone pressure was reported to be of normal gradient. In light of the foregoing, operators are advised to:

4. Review new northeast British Columbia well locations thoroughly for the presence of bedrock lows and any indication of Quaternary gravels.
5. Design drilling programs with the expectation of encountering shallow Quaternary gravel gas in 94-P and 94-I. Serious consideration should be given to the use of diverters on subject area surface holes.
6. Take and monitor sample cuttings from the surface where gas bearing Quaternary gravels are anticipated and to have gas detection equipment operational.
7. Utilize "main" hole drilling practices on surface holes in this area (i.e. blowout prevention drills, trip sheets, avoid the pumping out of singles and possible resulting charge up of zones, etc).



Operators are also reminded of the standing requirement to run a gamma-ray log from total depth to surface (open-hole, cased-hole or Measurement While Drilling), data which may prove useful in the identification of shallow gas zones for the programming of future wells. The log data will assist industry and operators in mapping the gas-bearing gravel formations.

It is also noteworthy some recent well control problems have been experienced in shallower zones in other areas of British Columbia. The offending zones are thought to be Quaternary gravels or possibly the Dunvegan zone, but the source of the gas therein is uncertain at this time.

## Appendix D: Classification of Low and Medium Risk Gas Wells

High Risk gas wells are gas wells classified as special sour or are acid gas disposal wells.

Medium Risk gas wells are gas wells where the maximum stabilized wellhead AOF exceeds the Maximum Allowable Flowrate of 28,000 m<sup>3</sup>/day (as per Figure D-1), are not classified as High Risk gas wells, and any Low Risk well that became inactive on or before 2009-05-30.

Maximum Allowable Flowrate (10<sup>3</sup>m<sup>3</sup>/day) = 15 x 10<sup>3</sup> / H<sub>2</sub>S Concentration (ppm).

Low Risk gas wells are gas wells that are not classified as Medium or High Risk.

**Figure D-1: Classification of Low and Medium Risk Gas Wells (Adopted from AER Directive 13).**

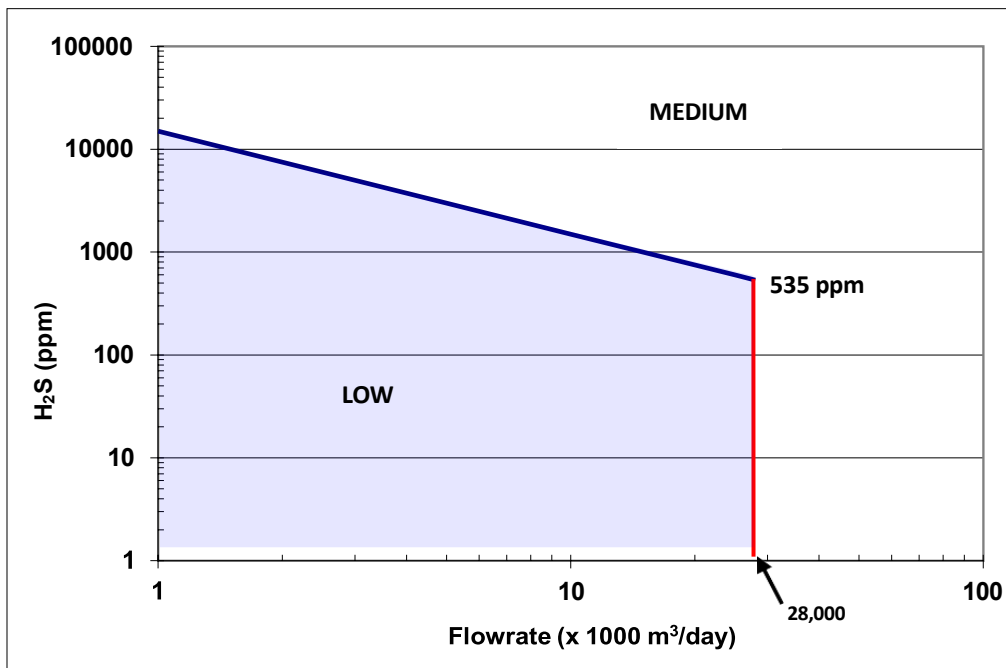

## Appendix E: Technical Guidance for Determining the “Base of Usable Groundwater”

The “base of usable groundwater” can be determined by the qualified professional, supported by review and analysis of local or site specific information, such as geology and stratigraphy, mapped aquifers, groundwater chemistry, or other data may be available through DataBC, iMapBC, or Regulator well information. For this interpretation of the “base of usable groundwater”, “usable” is defined by the Regulator as groundwater with up to 4000 mg/L total dissolved solids.

Alternatively, the “base of usable groundwater” can be determined by the qualified professional, using the definition of “deep groundwater” in Section 51 of the [Water Sustainability Regulation](#). Using this approach, the “base of usable groundwater” is defined as: between 300 m and 600 m below the ground surface, and below the “base of fish scales marker” or an identified older geological marker. The definition for “base of fish scales marker” can be found in the Water Sustainability Regulation.

For clarity, when using the geological marker based approach:

- The minimum depth of the “base of usable groundwater” is 300 m below the ground surface.
- The maximum depth of the “base of usable groundwater” is 600 m below the ground surface.
- Between 300 m and 600 m below the ground surface, the “base of usable groundwater” is identified to be the depth of the above-referenced geological markers. The geological marker may be interpreted using well site data, or data from nearby oil and gas wells, available as Regulator well information or information sourced from commercial data vendors such as Acumap or Geosout.

The above geological marker-based framework applies only to the “subject area”. For reference, “subject area” is defined in Section 51 or the Water Sustainability Regulation, and consists of the area east of the Laramide Disturbed Belt boundary (see map). Outside of the “subject area”, the “base of usable groundwater” is considered to be 600 m below the ground surface.

Note the technical guidance for determining the “base of usable groundwater” outlined in this section may not be suitable for locations of shallow gas potential or known areas of artesian groundwater pressures. The Regulator should be contacted in such cases regarding proposed well drilling and completion.

The Regulator may request permit holders to submit documentation of the qualified professional’s determination of the “base of usable groundwater”.

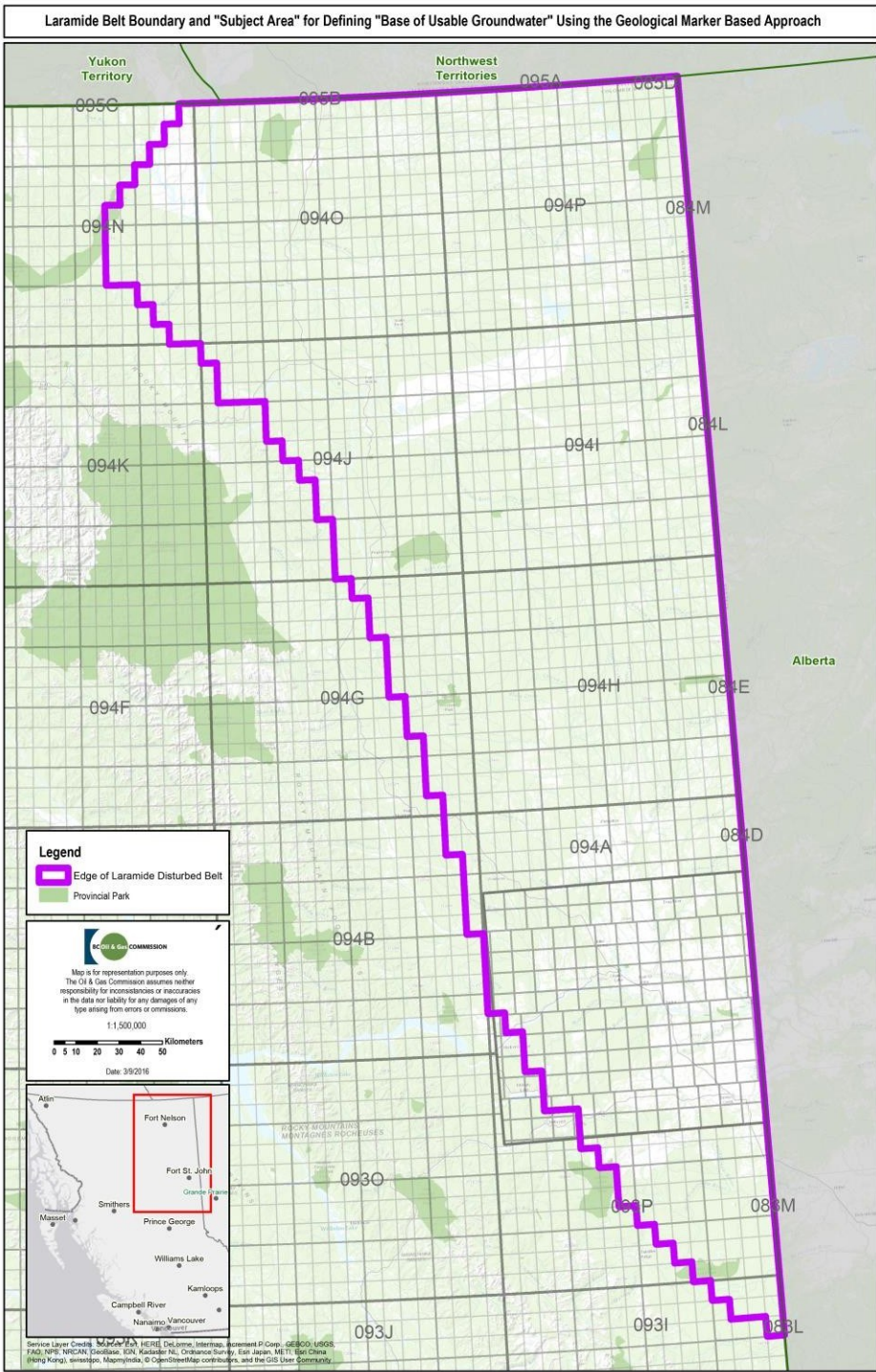

## Appendix F: Facility Changes Requiring an Amendment

The following lists equipment and examples of facility changes requiring the submission of a facility permit amendment for the addition of temporary or permanent equipment on Crown or private land.

- Amine sweetening package - process gas
- Amine sweetening package - fuel gas
- Bullet - condensate storage
- Bullet - LPG storage
- Capacity - gas/liquids throughput permit increase
- Compressor
- Condensate stabilization unit
- Debutanizer unit
- Deethanizer unit
- Depropanizer unit
- Dehydrator - glycol (process & fuel gas)
- Dehydrator - molecular sieve
- Flare stack
- Generator - (gas/diesel) except for those where the facility remains classified under Section 4 of the Oil & Gas Waste Regulation.
- Permitted H<sub>2</sub>S increase
- Incinerator
- Pump (used to transport hydrocarbon liquid (oil, LPV or HPV) in a pipeline, or pump fresh water)
- Pump jack (gas and electric)
- Process refrigeration unit
- Production Storage Tank
- Treater - Oil

## Appendix G: Facility Changes Where No Amendment or NOI is Needed

The following list includes examples of facility changes that do not require a Notice of Intent or amendment. These changes can be made under the authority of the existing facility permit (if not requiring new land).

- Analyzer
- Blow Case (without compressor)
- Coalescer
- Dehydrator - instrument air
- Electrical transformer & other power conversion equipment
- Field header
- Filter
- Generator - solar/fuel cell
- Generator - thermo electric
- Heater
- Instrument air compressor unit
- Line heater
- Meter
- Odourization pot
- Other/miscellaneous – minor
- Plunger Lift
- Pump (except those referenced in Appendix F)
- Scrubber including H<sub>2</sub>S Scavenger units
- Separator package (ie: test or group)

## Appendix H: Piping and Instrumentation Diagram (P&ID)

Piping and Instrumentation Diagram (P&ID) P&ID must be legible and identify each segment of pipe, including new pipe being built in existing right-of-ways in the project description and piping and instrumentation diagram. The minimum requirements for P&IDs are:

- All pipelines which are part of the permit are shown, including their connections (input and output).
- All segment breaks indicated and segments labelled (by project/segment if known, otherwise by Application Determination (AD) number if known, future input or other regulator if currently no AD number or project number).
- Facility and pipeline breaks, if applicable, clearly indicated.
- Spec breaks and class location changes indicated.
- Valves, fittings, flanges, etc. shown.
- Risers indicated with locations.
- Flow direction indications/arrows.
- Any equipment or pressure control directly on the pipeline, including setpoints. (Note pressure control can be on the facility drawings, in which case a separate pressure control attachment can be provided).
- Pipeline fluid or fluids, maximum permitted H<sub>2</sub>S and MOP.
- Pipeline OD (outside diameter) and WT (wall thickness).
- Drawing cross-references. Indicate on the drawing the line continued on so it is traceable.
- Drawing number, revision number and date.

Riser locations or installations directly supporting the pipeline are considered part of the pipeline and should be included in the pipeline and instrumentation design. Installation types included on a pipeline application include:

- Pump
- Storage vessel/tank
- Regulator
- Riser
- Pressure control/pressure protection valves/devices
- Isolation valves showing the physical location.  
(If applicable, the distance between valves and relation to major water crossings is to be determined)
- Farm taps
- Line heater

- Flaring
- Generator

Anything directly supporting the pipeline is considered part of the pipeline. Installations not included in the list should be shown on the P&ID and may be included as part of the facility application.



## Appendix I: Sour Well Information Form

To apply for the de-classification of a special sour well, the permit holder must submit a request via email to [Drilling.Production@bc-er.ca](mailto:Drilling.Production@bc-er.ca), and include the Sour Well Information Form listed below.

### Sour Formations

Formation Name	Max H <sub>2</sub> S Concentration (%)

### Critical features

Critical Feature Type	# within Completion EPZ

Max Completion H<sub>2</sub>S Release Rate (m<sup>3</sup>/sec)

Calculated Completion EPZ (km)

Nearest Occupied Dwelling (km)

Nearest Urban Centre (km)

Nearest School (km)

Nearest Populated Area (km)

Nearest Populated Area Name

## Appendix J: Benzene Emissions from Glycol Dehydrators

This information sets out the rationale and requirements for controlling the emissions of benzene from glycol dehydrators.

Benzene is classified as a toxic substance under the Canadian Environmental Protection Act and as a group one carcinogen by the International Agency for Research on Cancer. As a non-threshold carcinogen, there is considered to be some health risk at any level of exposure. As a result, benzene emissions must be managed to achieve the lowest levels practicable to minimize human exposure. The health risk posed by benzene is to be managed by reducing human exposure to the extent possible and practicable.

The Regulator is committed to reducing benzene emissions from glycol dehydrators.

In order to reduce and manage benzene emissions from glycol dehydrators in British Columbia, permit holders must comply with the following requirements:

- Permit holders must ensure all dehydrators meet the following benzene emissions limits:

Date of Installation or Relocation	Benzene Emissions Limit
Prior to January 1, 1999	5 tonnes/yr
a) Greater than 750 m to the nearest permanent resident or public facility	3 tonnes/yr
b) Less than 750 m to the nearest a permanent resident or public facility	
January 1, 1999 to June 30, 2007	3 tonnes/yr
After June 30, 2007	1 tonne/yr

- If more than one dehydrator is located at a facility or lease site, the cumulative benzene emissions for all dehydrators must not exceed the limit of the oldest dehydrator on site. Modifications may be required to existing units to meet the site limit.
- Any new or relocated dehydrators added to an existing site with dehydrators must operate at a maximum benzene emission limit of 1 tonne/yr or less. The cumulative benzene emissions must not exceed the limit of the oldest dehydrator on site.
- For dehydrators that are only in operation for a portion of the year, the benzene emission rate must be prorated.

Permit holders must complete a DEOS (Dehydrator Engineering and Operations Sheet to determine the benzene emissions from each dehydrator. The sheet must be posted at the dehydrator for use by operations staff and inspection by the Regulator. The DEOS must be revised once each calendar year or upon a change in operation status of a dehydrator.

Permit holders must complete and submit an annual Dehydrator Benzene Inventory List via eSubmission by March 31<sup>st</sup> of each calendar year for the operations of the previous calendar year.

For further clarification and/or information, contact the Regulator's Environmental Stewardship Group.