

Appendix B: Diagrams of Blowout Prevention Systems for Well Servicing

Figure B-1 Equipment Symbols

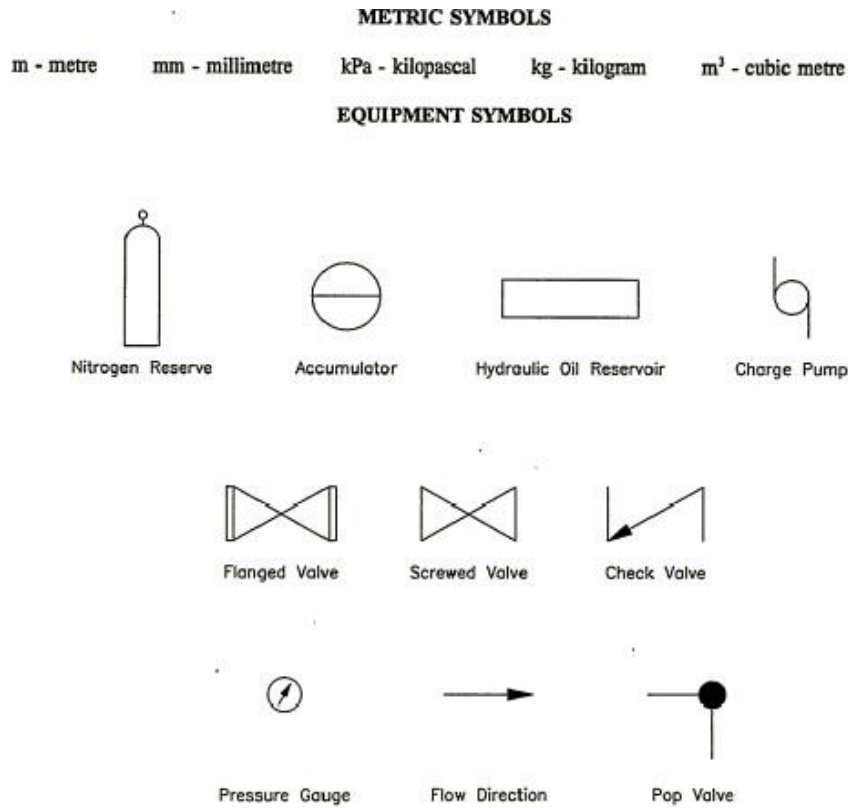

RATING OF PRODUCTION CASING FLANGE IS LESS THAN OR EQUAL TO 21000 kPa
 H_2S CONTENT OF THE GAS IS LESS THAN 10 MOLES/KILOMOLE

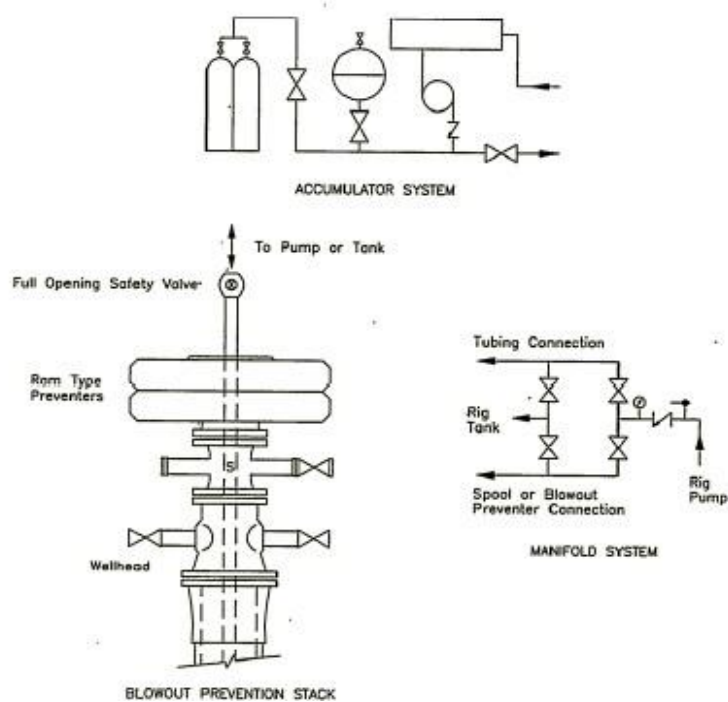

Figure B-2: BOP Class A Pressure Rating and Component Placement

- Pressure rating of preventers is equal to or greater than the production casing flange rating or the formation pressure, whichever is the lesser.
- 50 mm lines throughout.
- The positioning of the tubing and blind rams may be interchanged.
- Spool may have threaded side outlet (and valve) if wellhead has threaded fittings.
- A flanged BOP port (and valve) below the lowest set of rams may replace spool (valve may be threaded if wellhead has threaded fittings).

Rating of production casing flange is greater than 21 000 kPa or rating of production casing flange is less than or equal to 21 000 kPa and the H_2S content of the gas is equal to or greater than 10 MOLES per KILOMOLE.

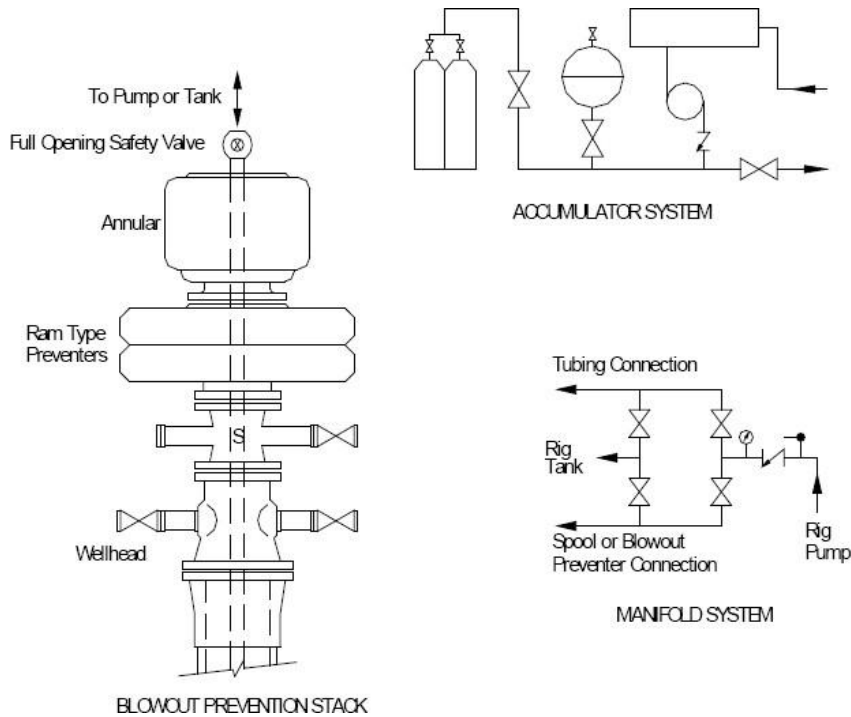

Figure B-3: BOP Class B Pressure Rating and Component Placement

- Pressure rating of preventers is equal to or greater than the production casing flange rating or the formation pressure, whichever is the lesser.
- 50 mm lines throughout.
- The positioning of the tubing and blind rams may be interchanged.
- Spool may have threaded side outlet (and valve) if wellhead has threaded fittings.
- A flanged blowout preventer port (and valve) below the lowest set of rams may replace spool (valve may be threaded if wellhead has threaded fittings.)

CLASS C - WELLHEAD CONFIGURATIONS
Special sour well servicing BOP stack with shear blind ram.

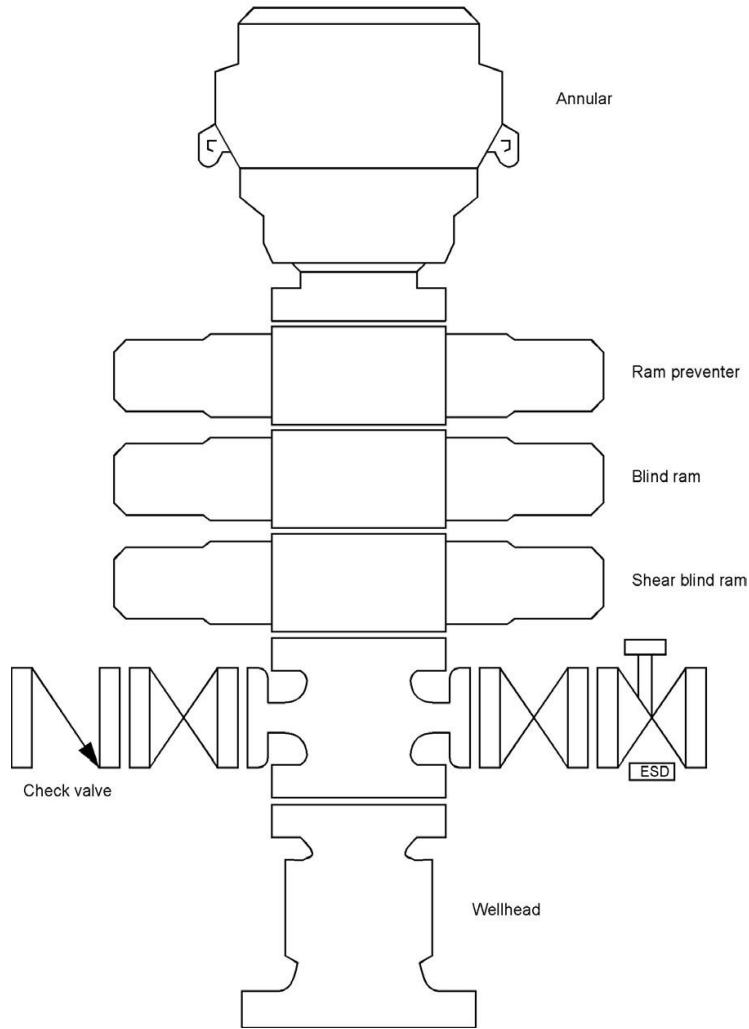

Figure B-4: BOP Class C Wellhead Configuration

CLASS C - WELLHEAD CONFIGURATIONS
Special sour well servicing BOP stack with shear blind ram optional arrangement.

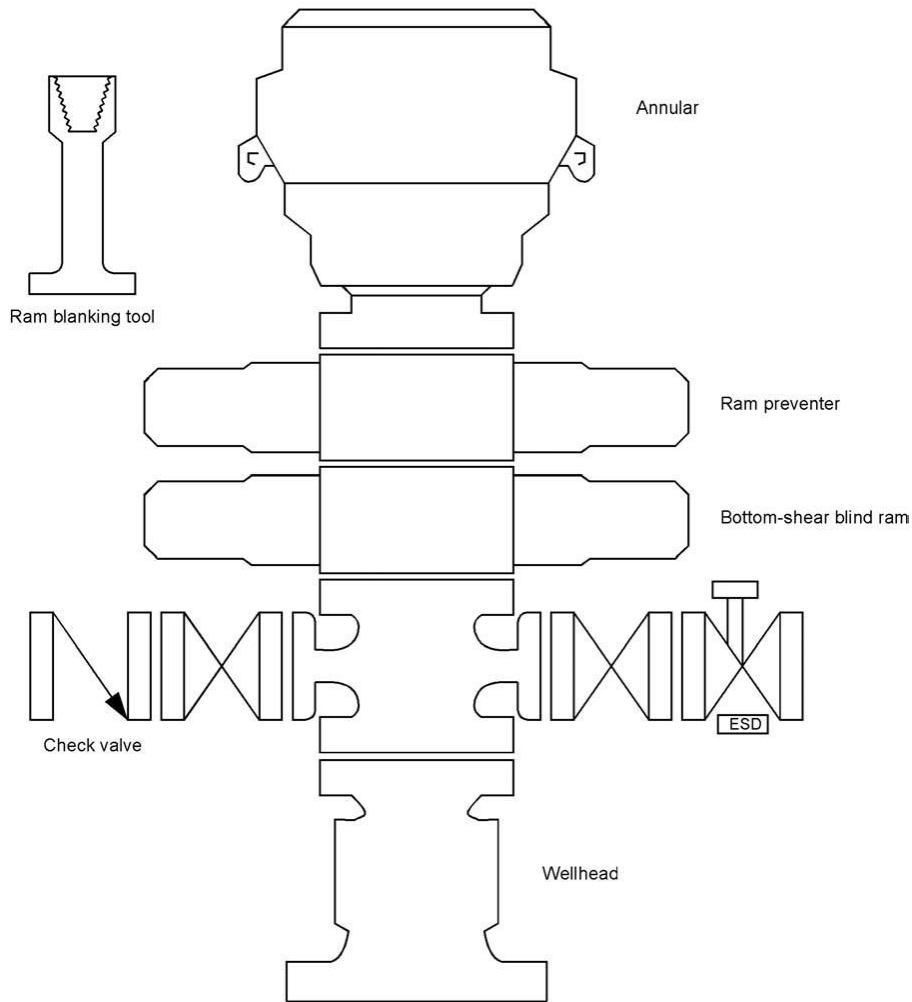

Figure B-5: BOP Class C Optional Wellhead Configuration